

ALL RIGHTS RESERVED. NO PORTION OF THIS PUBLICATION, WHETHER IN WHOLE OR IN PART CAN BE REPRODUCED WITHOUT THE EXPRESS WRITTEN CONSENT OF SPC TECHNOLOGY.

SPC TYPE NO.	VOLTS	AMPS	WATTS	MSCP	FILAMENT	LCL	LIFE (HOURS)
43	2.5	0.5	1.25	0.5	C-2R	0.78	3000
44	6.3	0.25	1.575	0.9	C-2R	0.78	3000
47	6.3	0.15	0.945	0.5	C-2R	0.78	3000
49	2	0.06	0.12	0.04	S-2	N/A	1000
239	6.3	0.36	2.268	N/A	C-2R	0.6	5000
313	28	0.17	4.76	3.5	C-2F	0.63	500
755	6.3	0.15	0.945	0.33	C-2R	0.78	20000
756	14	0.08	1.12	0.31	C-2F	0.63	15000
757	28	0.08	2.24	0.62	C-2F	0.63	7500
1490	3.2	0.16	0.512	0.2	C-2R	0.78	3000
1813	14.4	0.1	1.44	0.86	C-2V	0.63	1000
1815	14	0.2	2.8	1.4	C-2V	0.75	3000
1816	13	0.33	4.29	3	C-2V	0.63	1000
1818	24	0.17	4.08	3.3	C-2V	0.63	250
1819	28	0.04	1.12	0.34	C-2F	0.63	2500
1820	28	0.1	2.8	1.6	C-2F	0.63	1000
1822	36	0.1	3.6	2.1	C-2F	0.63	1000
1828	37.5	0.05	1.875	0.65	C-2R	0.63	3000
1829	28	0.07	1.96	1	C-2F	0.63	1000
1835	55	0.05	2.75	1.1	C-5	0.63	5000
1847	6.3	0.15	0.945	0.38	C-2R	0.78	5000
1850	5	0.09	0.45	0.25	C-2R	0.63	1500
1864	28	0.17	4.76	3	C-2F	0.63	1500
1866	6.3	0.25	1.575	0.65	C-2R	0.78	5000
1891	14	0.24	3.36	2	C-2F	0.63	500
1893	14	0.33	4.62	2	C-2F	0.63	7500
1892 (lamp)	14.4	0.12	1.73	0.75	C-2F	0.63	1000
8-3995	130	0.02	2.6	0.2	C-5	0.63	2000

REVISONS		DOC. NO. SPC-F005	* Effective: 12/21/98	* DCP No: 880				
DCP #	REV	DESCRIPTION	DRAWN	DATE	CHECKD	DATE	APPRVD	DATE
948	C	CREATE TABULAR SPEC	HYO	6/27/00	JC	10/4/00	JC	10/4/00
1281	D	Correct Part No.	HYO	11/28/01	JC	11/28/01	JC	11/28/01

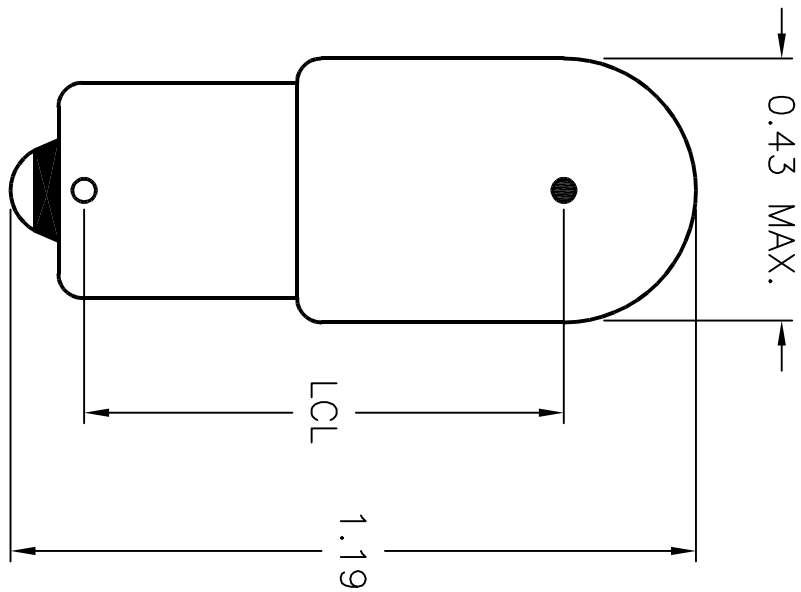

DISCLAIMER:
 ALL STATEMENTS AND TECHNICAL INFORMATION CONTAINED HEREIN ARE BASED UPON INFORMATION AND/OR TESTS WE BELIEVE TO BE ACCURATE AND RELIABLE SINCE CONDITIONS OF USE ARE BEYOND OUR CONTROL. THE USER SHALL DETERMINE THE APPROPRIATE PRODUCTION METHOD FOR THE INTENDED USE AND ASSUME ALL RISK AND LIABILITY WHATSOEVER IN CONNECTION THEREWITH.

UNLESS OTHERWISE SPECIFIED, DIMENSIONS ARE FOR REFERENCE PURPOSES ONLY.

DRAWN BY:	DATE:
J.C.	2/4/93
CHECKED BY:	DATE:
J.P.	2/8/93
APPROVED BY:	DATE:
J.L.	2/9/93



DRAWING TITLE: T 3- 1/4 MINIATURE BAYONET BASE LAMP

SIZE	DWG. NO.	ELECTRONIC FILE	REV
A	TA-268	TA-268.DWG	D
SCALE:	NTS	U.O.M.: INCHES	SHEET: 1 OF 1